

Utensileria e Cassettiere

14

*OUTILS ET COMMODES
TOOLS AND MOBILE ROLLER CABS
WERKZEUGEN UND KOMMODEN
HERRAMIENTAS Y CAJONERAS*



Ricambi macchine agricole e giardinaggio

www.cermag.com

CHIAVI COMBinate

COMBINATION WRENCHES



UNI 6741 - DIN 3113 - ISO 7738 Rif. BETA: 42

ARTICOLO	mm	L mm
70001	5,5x5,5	95
70002	6x6	95
70003	7x7	105
70004	8x8	116
70005	9x9	127
70006	10x10	137
70007	11x11	148
70008	12x12	158
70009	13x13	169
70010	14x14	180
70011	15x15	190
70012	16x16	201
70013	17x17	212
70014	18x18	222
70015	19x19	233
70016	20x20	243
70017	21x21	254
70018	22x22	264
70019	23x23	275
70020	24x24	285
70021	25x25	296
70022	26x26	307
70023	27x27	317
70024	28x28	328
70025	29x29	338
70026	30x30	349
70027	32x32	370
70028	34x34	391
70029	35x35	412
70030	36x36	412
70031	38x38	433
70032	41x41	465



SERIE COMPOSTA DA 26 PZ. Rif. BETA: 42/S26

ARTICOLO	mm
70033	6-7-8-9-10-11-12-13 14-15-16-17-18-19-20 21-22-23-24-25-26-27 28-29-30-32



SERIE COMPOSTA DA 9 PZ. Rif. BETA: 42AS/B9

ARTICOLO	mm
70034	1/4-5/16-3/8-7/16-1/2 9/16-5/8-11/16-3/4

CHIAVI COMBinate LUCIDE

COMBINATION WRENCHES, BRIGHT CROME-PLATED



SERIE COMPOSTA DA 17 PZ. Rif. BETA: 42MP/S17

ARTICOLO	mm
70035	6-7-8-9-10-11-12-13 14-15-16-17-18-19-20 21-22

CHIAVI A FORCHETTA DOPPIE

DOUBLE OPEN END WRENCHES



UNI 6736 - DIN 3110 - ISO 10102 Rif. BETA: 55

ARTICOLO	mm	L mm
70036	4x5	100
70037	6x7	120
70038	8x9	140
70039	10x11	155
70040	12x13	170
70041	14x15	185
70042	16x17	202
70043	18x19	220
70044	20x22	236
70045	21x23	245
70046	24x26	262
70047	25x28	272
70048	27x29	284
70049	30x32	295
70050	34x36	325
70051	35x38	375
70052	41x46	425
70053	50x55	500
70054	55x60	500



SERIE COMPOSTE DA 8 PZ./12 PZ. Rif. BETA: 55/S8

ARTICOLO	mm
70055	6x7-8x9-10x11-12x13 14x15-16x17-18x19-20x22
70056	6x7-8x9-10x11-12x13 14x15-16x17-18x19-20x22 21x23-24x26 25x28-30x32

CHIAVI POLIGONALI DOPPIE CURVE

RING WRENCHES



UNI 6740 - DIN 838 - ISO 10104 Rif. BETA: 90

ARTICOLO	mm	L mm
70057	8x9	180
70058	10x11	195
70059	12x13	215
70060	14x15	230
70061	16x17	245
70062	18x19	265
70063	20x22	290
70064	21x23	300
70065	30x32	375



SERIE COMPOSTE DA 8/12 PZ. Rif. BETA: 90/S8-90/S12

ARTICOLO	mm
70066	6x7-8x9-10x11-12x13 14x15-16x17-18x19-20x22
70067	6x7-8x9-10x11-12x13 14x15-16x17-18x19-20x22 21x23-24x26 25x28-30x32

CHIAVI COMBinate A CRICCHETTO

REVERSIBLE RATCHETING COMBINATION WRENCHES



Rif. BETA: 142

ARTICOLO	mm	L mm
70068	6	135
70069	8	135
70070	10	158
70071	13	180
70072	14	190
70073	17	230
70074	19	245
70075	22	284
70076	24	324



SERIE COMPOSTA DA 6 PZ. Rif. BETA: 142/B6

ARTICOLO	mm
70077	8-10-13-14-17-19

CHIAVI COMBinate A CRICCHETTO SNODATE

SWIVEL END RATCHETING COMBINATION WRENCHES



Rif. BETA: 142SN

ARTICOLO	mm	L mm
70078	8	136
70079	9	143
70080	10	161
70081	11	169
70082	12	175
70083	13	178
70084	14	194
70085	15	201
70086	16	217
70087	17	233
70088	18	238
70089	19	250

CHIAVI A "T" SEMPLICI ESAGONALI

T-HANDLE HEXAGON SOCKET WRENCHES

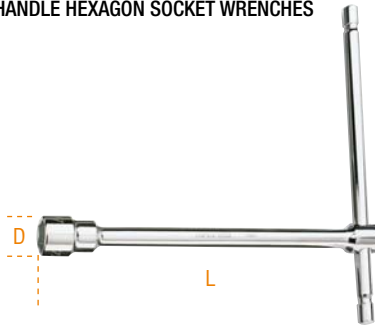

Rif. BETA: 950

ARTICOLO	mm	L mm	D mm
70097	7	212	11,2
70098	8	220	12,4
70099	10	230	14,9
70100	11	233	16,1
70503	12	240	17,5
70101	13	244	19,7
70504	14	250	20,1
70102	17	264	24,1
70103	19	274	26,6

CHIAVI A "T" CON BUSSOLA ESAGONALE SNODATA

T-HANDLE WRENCHES WITH SWIVELLING HEXAGON
SOCKET



UNI 6743

Rif. BETA: 952

ARTICOLO	mm	D mm	L mm
70104	7	10,7	395
70105	8	12,1	395
70106	10	14,6	400
70107	11	15,8	400
70108	13	18,7	432
70109	14	19,7	432
70110	17	23,4	450
70111	19	26,0	500

SERIE COMPOSTA DA 12 PZ. Rif. BETA: 142SN/S13

ARTICOLO	mm
70090	7-8-9-10-11-12-13-14 15-16-17-18-19

CHIAVI A TUBO DOPPIE POLIGONALI SERIE PESANTE

DOUBLE ENDED BI-HEX TUBULAR SOCKET WRENCHES,
HEAVY SERIES



UNI 6745

Rif. BETA: 930

ARTICOLO	mm	L mm
70091	10x11	116
70092	12x13	124
70093	14x15	132
70094	16x17	140
70095	18x19	148
70096	20x22	156

SERIE COMPOSTA DA 7 PZ. Rif. BETA: 952/S7

ARTICOLO	mm
70112	8-10-11-13-14-17-19

CHIAVI A BUSSOLA ESAGONALE CON IMPUGNATURA BIMATERIALE TIPO LUNGO

HI-TORQUE HEXAGON NUT SPINNERS, LONG SERIES

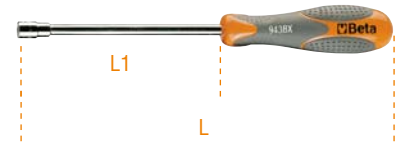

UNI 6750

Rif. BETA: 943BX

ARTICOLO	mm	L mm	L1 mm
70113	4	270	150
70114	5	270	150
70115	5,5	270	150
70116	6	270	150
70117	7	270	150
70118	8	282	150
70119	9	282	150
70120	10	282	150
70121	11	282	150
70122	12	282	150
70123	13	282	150
70124	14	282	150



SERIE COMPOSTA DA 11 PZ. Rif. BETA: 943BX/S12

ARTICOLO	mm
70125	4-5-5,5-6-7-8-9-10-11 12-13-14

CHIAVI A BUSSOLA ESAGONALE FLESSIBILI CON IMPUGNATURA

FLEXIBLE NUT SPINNERS WITH HANDLES



UNI 6750

Rif. BETA: 943FL

ARTICOLO	mm	L mm	L1 mm
70126	5	265	150
70127	5,5	265	150
70128	6	265	150
70129	7	265	150
70130	8	265	150
70131	10	290	175

CHIAVI A CROCE PER DADI RUOTE FOUR-WAY HEXAGON WHEEL NUT WRENCHES, CHROME-PLATED

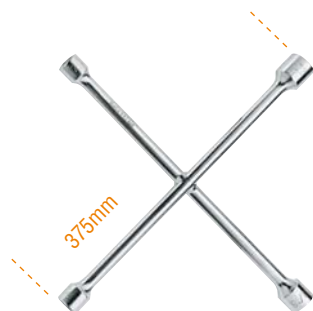

UNI/ISO 6788 - DIN 3119 Rif. BETA: 978

ARTICOLO	mm
70132	17x19x21x22

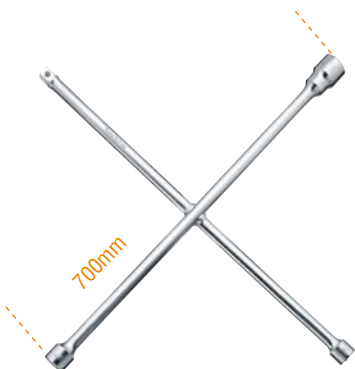

UNI/ISO 6788 - DIN 3119 Rif. BETA: 982

ARTICOLO	mm
70133	24x27x32x33/4

13 CHIAVI A BUSSOLA ESAGONALI E 5 ACCESSORI ASSORTMENT OF 13 HEXAGON SOCKETS AND 5 ACCESSORIES

1/4"



Rif. BETA: 900/C13-5

ARTICOLO	mm
70134	4-4,5-5-5,5-6-7-8-9 10-11-12-13-14

CHIAVI A BUSSOLA A MANO BOCCA ESAGONALE HEXAGON HAND SOCKETS



Rif. BETA: 910A

ARTICOLO	mm	D mm	L mm
70135	6	9,5	28
70136	7	10,7	28
70137	8	12,1	28
70138	9	13,2	28
70139	10	14,6	29
70140	11	15,8	29
70141	12	17,2	30
70142	13	18,4	31
70143	14	19,7	32
70144	15	20,9	32
70145	16	22,2	33
70146	17	23,2	33
70147	18	24,7	34
70148	19	25,8	35
70149	20	27,2	35
70150	21	28,2	36
70151	22	29,7	37

SNODO CON ATTACCHI QUADRI MASCHIO E FEMMINA 3/8" DRIVE UNIVERSAL JOINT, CHROME-PLATED



3/8"

UNI/ISO 3316 - DIN 3123 Rif. BETA: 910/25

ARTICOLO	L mm	D mm
70466	54,6	19

CRICCHETTO REVERSIBILE CON ATTACCO QUADRO MASCHIO 3/8" MECCANISMO A 48 DENTI 3/8" DRIVE REVERSIBLE RATCHET, 48 TEETH, CHROME-PLATED



3/8"

UNI/ISO 3315 - DIN 3122 Rif. BETA: 910/55Q

ARTICOLO	L mm	Ø mm	A mm
70152	200	30	33

RACCORDO CON ATTACCO QUADRO FEMMINA 1/2" E MASCHIO 3/8" ADAPTOR, 1/2" FEMALE AND 3/8" MALE DRIVES



UNI/ISO 3316 - DIN 3123 Rif. BETA: 920/15

ARTICOLO	L mm	D mm
70467	42	22

16 CHIAVI A BUSSOLA ESAGONALI E 5 ACCESSORI ASSORTMENT OF 15 HEXAGON SOCKETS AND 5 ACCESSORIES

3/8"



Rif. BETA: 910A/C16Q

ARTICOLO	mm
70153	6-7-8-9-10-11-12-13 14-15-16-17-18-19 21-22

CHIAVI A BUSSOLA A MANO BOCCA ESAGONALE

HEXAGON HAND SOCKETS



Rif. BETA: 920A

ARTICOLO	mm	D mm	L mm
70154	8	12,4	38
70155	9	13,5	38
70156	10	14,9	38
70157	11	16,1	38
70158	12	17,5	38
70159	13	18,7	38
70160	14	20,1	38
70161	15	21,5	38
70162	16	22,7	38
70163	17	24,1	38
70164	18	25,3	39
70165	19	26,6	39
70166	20	27,8	40
70167	21	28,8	40
70168	22	29,9	41
70169	23	30,8	42
70170	24	32,2	43
70171	25	33,2	44
70172	26	34,7	45
70173	27	36,2	46
70174	28	37,2	47
70175	29	38,6	48
70176	30	40,2	48
70177	32	42,3	49

CHIAVE A BUSSOLA CON ATTACCO QUADRO FEMMINA PER INIETTORI MOTORI DIESEL

1/2" SQUARE DRIVE SOCKET FOR DIESEL ENGINE INJECTORS, CHROME-PLATED, BI-HEX



Rif. BETA: 960A

ARTICOLO	mm	D mm	L mm
70178	27	36,5	77

SNODO CON ATTACCHI QUADRI MASCHIO FEMMINA 1/2"

1/2" DRIVE UNIVERSAL JOINT, CHROME-PLATED



UNI/ISO 3316 - DIN 3123 Rif. BETA: 920/25

ARTICOLO	L mm	D mm
70469	75	27

CRICCHETTO REVERSIBILE CON ATTACCO QUADRO MASCHIO 1/2" MECCANISMO A 48 DENTI

1/2" DRIVE REVERSIBLE RATCHET, 48 TEETH, CHROME-PLATED



UNI/ISO 3315 - DIN 3122 Rif. BETA: 920/55Q

ARTICOLO	L mm	Ø mm	A mm
70179	275	40	43

12 CHIAVI A BUSSOLA ESAGONALI E 5 ACCESSORI

ASSORTMENT OF 12 HEXAGON SOCKETS AND 5 ACCESSORIES



Rif. BETA: 920A/C12

ARTICOLO	mm
70180	10-11-12-13-14-17-19 22-24-27-30-32

20 CHIAVI A BUSSOLA ESAGONALI E 5 ACCESSORI

ASSORTMENT OF 20 HEXAGON SOCKETS AND 5 ACCESSORIES



Rif. BETA: 920A/C20X

ARTICOLO	mm
70181	10-11-12-13-14-15-16 17-18-19-20-21-22-23 24-26-27-28-30-32

CHIAVI A BUSSOLA A MANO BOCCA ESAGONALE

SQUARE DRIVE SOCKETS, HEXAGON ENDS, CHROME-PLATED



Rif. BETA: 928A

ARTICOLO	mm	D mm	L mm
70182	19	29,2	50
70183	22	31,3	53
70184	24	34,5	53
70185	27	38,0	56
70186	30	41,5	58
70451	32	44,3	60
70187	34	46,8	60
70188	36	49,5	64
70189	38	52,0	68
70190	41	56,0	71
70191	46	62,3	75
70192	50	67,4	80
70193	55	73,7	84

CHIAVI A BUSSOLA MASCHIO ESAGONALE

SOCKET DRIVERS FOR HEXAGON SCREWS, 3/4" FEMALE SQUARE DRIVE



Rif. BETA: 928ME

ARTICOLO	mm	D mm	L mm
70194	14	35	75
70195	17	35	75

PROLUNGHE CON ATTACCHI QUADRI MASCHIO E FEMMINA

DRIVE EXTENSION BARS, CHROME-PLATED



Rif. BETA: 928/21 - 928/22

ARTICOLO	L mm	D mm
70196	200	34
70197	380	34

RACCORDO CON ATTACCO QUADRO FEMMINA 1/2" E MASCHIO 3/4"

ADAPTOR, 1/2" FEMALE AND 3/4" MALE DRIVES



3/4"

D

L

UNI/ISO 3316 - DIN 3123 Rif. BETA: 920/16

ARTICOLO	L mm	A mm
70468	46	26

QUADRO MASCHIO CON SPINA SCORREVOLE

DRIVE SLIDE T-HANDLE, CHROME-PLATED

3/4"



Rif. BETA: 928/42

ARTICOLO	L mm
70198	450

CRICCHETTO REVERSIBILE CON ATTACCO QUADRO MASCHIO 3/4" MECCANISMO A 72 DENTI

3/4" DRIVE REVERSIBLE RATCHET, 72 TEETH, CHROME-PLATED



3/4"

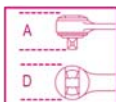

Rif. BETA: 928/55

ARTICOLO	L mm	D mm	A mm
70482	510	58	59

12 CHIAVI A BUSSOLA ESAGONALI E 5 ACCESSORI

ASSORTMENT OF 12 HEXAGON SOCKETS AND 5 ACCESSORIES

3/4"



Rif. BETA: 928A/C12

ARTICOLO	mm
70199	22-24-27-30-32-34-36-38-41-46-50-55

CHIAVI DINAMOMETRICHE A SCATTO CON CRICCHETTO REVERSIBILE PER SERRAGGI DESTROSI, PRECISIONE DI SERRAGGIO ±4%

CLICK-TYPE TORQUE WRENCHES WITH REVERSIBLE RATCHETS FOR RIGHT-HAND TIGHTENING TORQUE ACCURACY ±4%



UNI EN 26789 - ISO 6789

Rif. BETA: 606/6 - 606/10X - 606/20

ARTICOLO	kgfm	lbf.ft	■	D mm	H mm	L mm
70200	0,8÷6	6÷44	3/8	30	33	305
70201	2÷10	15÷80	1/2	30	37	345
70202	4÷20	30÷150	1/2	40	43	440

CHIAVI MASCHIO ESAGONALE PIEGATE TIPO LUNGO, CROMATE

OFFSET HEXAGON KEY WRENCHES, LONG SERIES, CHROME-PLATED



Rif. BETA: 96LC

ARTICOLO	mm	L mm	L1 mm
70203	3	126	20
70204	4	140	25
70205	5	160	28
70206	6	180	32
70207	7	190	34
70208	8	200	36
70209	10	224	40
70210	12	250	45



SERIE COMPOSTA DA 12 PZ. Rif. BETA: 96LC/SC12

ARTICOLO	mm
70211	2-2,5-3-3,5-4-4,5-5-6-7-8-9-10

CHIAVI MASCHIO ESAGONALE PIEGATE CON ESTREMITA SFERICA, CROMATE

BALL HEAD OFFSET HEXAGON KEY WRENCHES



SERIE COMPOSTA DA 9 PZ. Rif. BETA: 96BPC/SC9

ARTICOLO	mm
70212	1,5-2-2,5-3-4-5-6-8-10

CHIAVI MASCHIO ESAGONALE PIEGATE, CROMATE

OFFSET HEXAGON KEY WRENCHES



SERIE COMPOSTA DA 6 PZ. Rif. BETA: 96/ST6

ARTICOLO	mm
70213	2,5-3-4-5-6-8



SERIE COMPOSTA DA 10 PZ. Rif. BETA: 96/B10

ARTICOLO	mm
70214	1,5-2-2,5-3-4-5-6-8-10-12



SERIE COMPOSTA DA 12 PZ. Rif. BETA: 96/SC12

ARTICOLO	mm
70215	2-2,5-3-3,5-4-4,5-5-6-7-8-9-10

CHIAVI MASCHIO ESAGONALE PIEGATE BRUNITE

OFFSET HEXAGON KEY WRENCHES, BURNISHED



SERIE COMPOSTE DA 7 pz. Rif. BETA: 96N/G7 -G7A

ARTICOLO	mm
70216	2,5-3-4-5-6-8-10
70217	1,5-2-2,5-3-4-5-6



SERIE COMPOSTA DA 9 PZ. Rif. BETA: 96N/SC9

ARTICOLO	mm
70218	1,5-2-2,5-3-4-5-6-8-10



UNI 6753 - DIN 911 - ISO 2936 Rif. BETA: 96N

ARTICOLO	Ø mm	L mm	L1 mm
70452	2	50	16
70453	2,5	56	18
70454	3	63	20
70455	3,5	66	22
70456	4	70	25
70457	4,5	75	26
70458	5	80	28
70459	6	90	32
70460	7	95	34
70461	8	100	36
70462	9	106	38
70463	10	112	40
70464	11	119	42
70465	12	125	45

CHIAVI A "T" CON TRE ESTREMITÀ MASCHIO ESAGONALE

T-HANDLE WRENCHES WITH THREE HEXAGON MALE ENDS, CHROME-PLATED



Rif. BETA: 951

ARTICOLO	Ø mm	L mm	L1 mm
70219	2	125	63
70470	2,5	150	63
70220	3	150	63
70471	3,5	175	76
70221	4	175	76
70222	4,5	195	87
70223	5	195	87
70224	6	215	99
70225	7	230	109
70226	8	250	122
70472	9	265	132
70227	10	280	142
70228	12	305	160
70473	14	330	178

CHIAVI MASCHIO ESAGONALE PIEGATE CON IMPUGNATURA DI MANOVRA

OFFSET HEXAGON KEY WRENCHES, WITH HIGH TORQUE HANDLES



Rif. BETA: 96/T

ARTICOLO	Ø mm	L mm	L1 mm
70229	2	139	52
70230	2,5	153	55
70231	3	153	55
70232	3,5	179	70
70233	4	179	70
70234	4,5	200	84
70235	5	200	84
70236	6	220	95
70237	7	236	106
70238	8	255	114
70239	10	285	132



SERIE COMPOSTA DA 6 PZ. Rif. BETA: 96/T/S6

ARTICOLO	Ø mm
70240	2-2,5-3-4-5-6

CHIAVI MASCHIO PIEGATE CON IMPUGNATURA PER VITI CON IMPRONTA TORX®

OFFSET KEY WRENCHES, WITH HANDLES FOR TORX® HEAD SCREWS



Rif. BETA: 97TTX

ARTICOLO	Ø mm	L mm	L1 mm
70487	T6	130	52
70488	T7	130	52
70489	T8	139	52
70490	T9	139	52
70491	T10	179	70
70492	T15	179	70
70493	T20	179	70
70494	T25	179	70
70495	T27	200	84
70496	T30	200	84
70497	T40	221	103
70498	T45	236	106
70499	T50	255	117



SERIE COMPOSTA DA 11 PZ. Rif. BETA: 97TTX/S13

ARTICOLO	Ø mm
70241	T6-T7-T8-T9-T10-T15-T20-T25-T27-T30-T40-T45-T50

GIRAVITE PER VITI A TESTA CON INTAGLIO

SCREWDRIVERS FOR SLOTTED HEAD SCREWS



UNI 10562 - DIN 5265 - ISO 2380 Rif. BETA: 1260

ARTICOLO	SxAxL mm	L1 mm
70242	0,4x2,5x50	150
70243	0,4x2,5x75	175
70244	0,5x3x100	200
70245	0,6x3,5x75	175
70246	0,6x3,5x100	200
70247	0,8x4x100	208
70248	1x5,5x150	258
70249	1,2x6,5x150	269
70250	1,2x8x150	277
70251	1,2x8x200	327
70253	1,6x10x200	327

GIRAVITE PER VITI A TESTA CON INTAGLIO TIPO CORTISSIMO

SCREWDRIVERS FOR SLOTTED HEAD SCREWS, EXTRA-SHORT SERIES



UNI 10562 - DIN 5265 Rif. BETA: 1260N

ARTICOLO	SxAxL mm	L1 mm
70254	0,8x4x30	87
70255	1,2x6,5x30	87

GIRAVITE PER VITI CON IMPRONTA A CROCE PHILLIPS®

SCREWDRIVERS FOR CROSS HEAD PHILLIPS® SCREWS

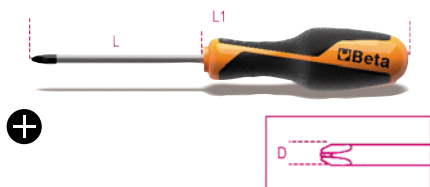

UNI/ISO 8764 - DIN 5262 Rif. BETA: 1262

ARTICOLO	PHxDxL mm	L1 mm
70256	0x3x60	160
70257	1x4,5x80	188
70258	2x6x100	219
70259	2x6x150	269
70260	3x8x150	277

SERIE 8 GIRAVITE

SET OF 8 SCREWDRIVERS



SERIE COMPOSTA DA 8 PZ. Rif. BETA: 1263/D8

ARTICOLO	⊖	⊕
70261	0,4x2,5x75 0,5x3x75 0,8x4x100 1,0x5,5x125 1,2x6,5x150	0x3x60 1x4,5x80 2x6x100

CHIAVI MASCHIO CON IMPUGNATURA PER VITI CON IMPRONTA TORX®

DRIVERS FOR TORX® HEAD SCREWS, WITH HANDLES



Rif. BETA: 1267TX

ARTICOLO	⊕	L mm	L1 mm
70262	T6	50	146
70263	T7	50	146
70264	T8	60	156
70265	T9	60	168
70266	T10	80	188
70267	T15	80	188
70268	T20	100	208
70269	T25	100	216
70270	T27	115	231
70271	T30	115	231
70272	T40	130	257
70273	T45	130	257

CHIAVI MASCHIO CON IMPUGNATURA PER VITI CON IMPRONTA TAMPER RESISTANT TORX®

SCREWDRIVERS FOR TAMPER RESISTANT TORX® HEAD
SCREWS



Rif. BETA: 1268RTX

ARTICOLO	⊕	L mm	L1 mm
70274	T9	60	168
70275	T10	80	188
70276	T15	80	188
70277	T20	100	208
70278	T25	100	208
70279	T27	115	231
70280	T30	115	231
70281	T40	130	257

GIRAVITE PER VITI A TESTA CON INTAGLIO

SCREWDRIVERS FOR SLOTTED HEAD SCREWS

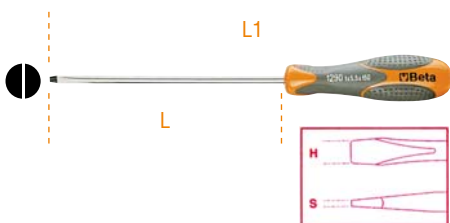

UNI 10562 - DIN 5265 - ISO 2380 Rif. BETA: 1290

ARTICOLO	SxHxL mm	L1 mm
70282	0,5x3x75	171
70283	0,5x3x125	221
70284	0,6x3,5x100	196
70285	0,8x4x100	196
70286	1x5,5x100	209
70287	1x5,5x200	309
70288	1,2x6,5x150	270
70289	1,2x8x200	332
70290	2x12x250	382

GIRAVITE PER VITI A TESTA CON INTAGLIO TIPO CORTISSIMO

SCREWDRIVERS FOR SLOTTED HEAD SCREWS, EXTRA-
SHORT SERIES

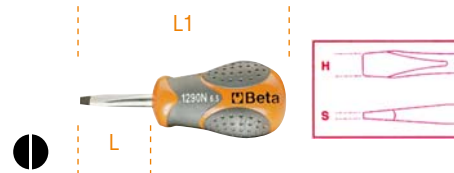

UNI 10562 - DIN 5265 Rif. BETA: 1290N

ARTICOLO	SxHxL mm	L1 mm
70291	0,8x4x30	86,1
70292	1,2x6,5x30	86,1

GIRAVITE PER VITI CON IMPRONTA A CROCE PHILLIPS®

SCREWDRIVERS FOR CROSS HEAD PHILLIPS® SCREWS

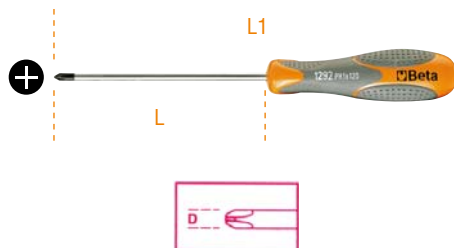

UNI/ISO 8764 - DIN 5262 Rif. BETA: 1292

ARTICOLO	PHxDxL mm	L1 mm
70293	0x3x100	196
70294	1x4,5x120	229
70295	1x4,5x150	259
70296	2x6x150	270
70297	3x8x150	282
70298	4x10x200	332

GIRAVITE PER VITI CON IMPRONTA A CROCE PHILLIPS® TIPO CORTISSIMO

SCREWDRIVERS FOR CROSS HEAD PHILLIPS® SCREWS
EXTRA SHORT SERIES



UNI/ISO 8764 - DIN 5262 Rif. BETA: 1292N

ARTICOLO	PHxDxL mm	L1 mm
70299	1x4,5x30	86,1
70300	2x6x30	86,1

MICROGIRAVITE PER VITI SENZA TESTA CON INTAGLIO

MICRO SCREWDRIVER



Rif. BETA: 1257LP

ARTICOLO	SxD mm	L mm
70302	0,25x1,2	50
70303	0,23x1,5	50

GIRAVITE PROVACIRCUITO 6÷24V

CIRCUIT TESTING SCREWDRIVER 6-24V AMERICAN STANDARD

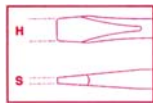

UNI 10562 - DIN 5265 - ISO 2380 Rif. BETA: 1254

ARTICOLO	SxHxL mm	L1 mm
70304	0,5x3x44	123

VALIGIA "HOME BAG" CON ASSORTIMENTO DI 24 UTENSILI

"HOME BAG" WITH ASSORTMENT OF 24 TOOLS



Rif. BETA: 2055

ARTICOLO	
70305	

CHIAVE A COMPASSO CON NASELLI TONDI

ROUND PIN WRENCH FOR RING NUTS WITH FRONT HOLES, CHROME-PLATED



Rif. BETA: 100

ARTICOLO	Ø mm	L mm
70306	4,9-5,9-6,9-7,9	250

KIT RICAMBI - SPARE PINS



Rif. BETA: 100/KIT

70307	naselli di ricambio
-------	---------------------

CHIAVI REGOLABILI A RULLINO CON SCALA GRADUATA

ADJUSTABLE WRENCHES WITH SCALES, CHROME-PLATED



UNI 6734 - DIN 3117 - ISO 6787 Rif. BETA: 111G

ARTICOLO	L mm	A max mm
70308	200	28
70309	250	34
70310	300	35

PINZE REGOLABILI VERNICIATE ARANCIO CERNIERA CHIUSA

SLIP JOINT PLIERS, VARNISHED ORANGE, BOXED JOINTS



UNI 8608 - DIN 8976 Rif. BETA: 1048V

ARTICOLO	L mm	A max mm	L1 mm
70311	250	48	39
70312	300	56	47

PINZE REGOLABILI AUTOBLOCCANTI GANASCE CONCAVE

ADJUSTABLE SELF-LOCKING PLIERS, CONCAVE JAWS, CHROME-PLATED



UNI 8608 - DIN 8976 Rif. BETA: 1052

ARTICOLO	L ~ mm	A max mm
70313	190	36
70314	240	42

GIRATUBI MODELLO SVEDESE GANASCE SOTTILI A 45°

PIPE WRENCHES, SWEDISH PATTERN, 45°, SLIM JAWS



Rif. BETA: 374

ARTICOLO	Ø	L mm
70315	1/2" gas - 22 mm	265
70316	1" gas - 34 mm	340
70317	1" 1/2 gas - 49 mm	435
70318	2" gas - 60 mm	550
70319	3" gas - 90 mm	700

GIRATUBI REVERSIBILI A NASTRO

REVERSIBLE STRIP PIPE WRENCHES, FORGED STEEL LEVER



Rif. BETA: 383

ARTICOLO	Ø	L mm
70320	3" gas - 90 mm	300
70321	8" gas - 220 mm	300

GIRATUBO REVERSIBILE A CATENA

REVERSIBLE CHAIN PIPE WRENCH, FORGED STEEL LEVER



Rif. BETA: 384

ARTICOLO	Ø	L mm
70322	4" gas - 115 mm	300

PINZE A BECCHI DRITTI PER ANELLI ELASTICI DI SICUREZZA PER FORI, MANICI RICOPERTI IN PVC

INTERNAL CIRCLIP PLIERS, STRAIGHT PATTERN, CHROME-PLATED, PVC-COATED HANDLES



UNI 7914 - DIN 5256 Rif. BETA: 1032

ARTICOLO	Ø mm	L mm
70323	8÷12	142
70500	12÷25	142
70324	19÷60	182
70325	40÷100	227
70326	85÷200	302

PINZE A BECCHI DRITTI PER ANELLI ELASTICI DI SICUREZZA PER ALBERI, MANICI RICOPERTI IN PVC

EXTERNAL CIRCLIP PLIERS, STRAIGHT PATTERN, CHROME-PLATED, PVC-COATED HANDLES



UNI 7915 - DIN 5254 Rif. BETA: 1036

ARTICOLO	Ø mm	L mm
70334	3÷10	142
70335	10÷25	142
70336	19÷60	177
70337	40÷100	227

PINZE UNIVERSALI CROMATE LUCIDE MANICI RICOPERTI CON 2 STRATI DI PVC ANTISCIVOLO

COMBINATION PLIERS, BRIGHT CHROME-PLATED, HANDLES COATED WITH 2 LAYERS OF ANTISLIP PVC

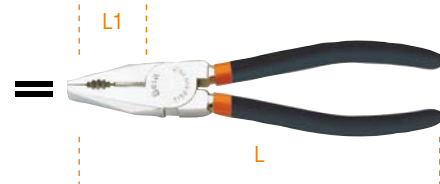

UNI 9894 - ISO 5746 Rif. BETA: 1150

ARTICOLO	L ~ mm	L1 mm	Ø mm
70346	200	43	2,0

PINZE A BECCHI PIEGATI A 45° PER ANELLI ELASTICI DI SICUREZZA PER FORI, MANICI RICOPERTI IN PVC

INTERNAL CIRCLIP PLIERS, BENT PATTERN, 45°, CHROME-PLATED, PVC-COATED HANDLES



UNI 7914 - DIN 5256 Rif. BETA: 1033

ARTICOLO	Ø mm	L mm
70327	8÷12	142
70501	12÷25	142
70328	19÷60	182
70329	40÷100	227

PINZE A BECCHI PIEGATI A 45° PER ANELLI ELASTICI DI SICUREZZA PER ALBERI, MANICI RICOPERTI IN PVC

EXTERNAL CIRCLIP PLIERS, BENT PATTERN, 45°, CHROME-PLATED, PVC-COATED HANDLES



UNI 7915 - DIN 5254 Rif. BETA: 1037

ARTICOLO	Ø mm	L mm
70338	3÷10	142
70339	10÷25	142
70340	19÷60	177
70341	40÷100	227

PINZE A BECCHI PIATTI LUNGHISSIMI DIRITTI ZIGRINATI MANICI RICOPERTI CON 2 STRATI DI PVC ANTISCIVOLO

EXTRA LONG FLAT KNURLED NOSE PLIERS, CHROME-PLATED, HANDLES COATED WITH 2 LAYERS OF ANTISLIP PVC

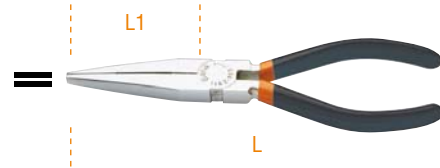

UNI 7925 Rif. BETA: 1162

ARTICOLO	L ~ mm	L1 mm	Ø mm
70347	200	76	1,6

PINZE A BECCHI PIEGATI A 90° PER ANELLI ELASTICI DI SICUREZZA PER FORI, MANICI RICOPERTI IN PVC

INTERNAL CIRCLIP PLIERS, BENT PATTERN, 90°, CHROME-PLATED, PVC-COATED HANDLES



UNI 7914 - DIN 5256 Rif. BETA: 1034

ARTICOLO	Ø mm	L mm
70330	8÷12	132
70502	12÷25	132
70331	19÷60	172
70332	40÷100	212
70333	85÷200	292

PINZE A BECCHI PIEGATI A 90° PER ANELLI ELASTICI DI SICUREZZA PER ALBERI, MANICI RICOPERTI IN PVC

EXTERNAL CIRCLIP PLIERS, BENT PATTERN, 90°, CHROME-PLATED, PVC-COATED HANDLES



UNI 7915 - DIN 5254 Rif. BETA: 1038

ARTICOLO	Ø mm	L mm
70342	3÷10	137
70343	10÷25	137
70344	19÷60	177
70345	40÷100	222

PINZE A BECCHI PIATTI LUNGHISSIMI PIEGATI ZIGRINATI MANICI RICOPERTI CON 2 STRATI DI PVC ANTISCIVOLO

EXTRA LONG BENT FLAT KNURLED NOSE PLIERS, CHROME-PLATED, HANDLES COATED WITH 2 LAYERS OF ANTISLIP PVC

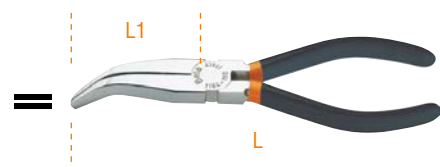

UNI 7925 Rif. BETA: 1164

ARTICOLO	L ~ mm	L1 mm	Ø mm
70348	200	70	1,6

PINZE A BECCHI MEZZOTONDI LUNGHISSIMI DIRITTI ZIGRINATI MANICI RICOPERTI CON 2 STRATI DI PVC ANTISCIVOLO

EXTRA LONG NEEDLE KNURLED NOSE PLIERS, CHROME-PLATED, HANDLES COATED WITH 2 LAYERS OF ANTISLIP PVC

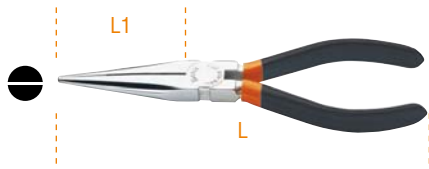

UNI 7926 - ISO 5745 Rif. BETA: 1166

ARTICOLO	L ~ mm	L1 mm	mm
70349	200	76	1,6

PINZE A BECCHI PIATTI LUNGHISSIMI DIRITTI ZIGRINATI IMPUGNATURA BIMATERIALE

EXTRA LONG FLAT KNURLED NOSE PLIERS BIMATERIAL HANDLES

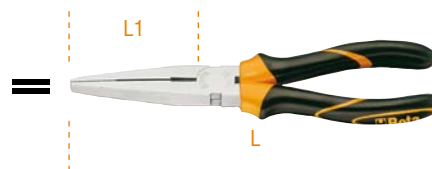

UNI 7925 Rif. BETA: 1162BM

ARTICOLO	L ~ mm	L1 mm	mm
70352	200	76	1,6

PINZE A BECCHI MEZZOTONDI LUNGHISSIMI PIEGATI ZIGRINATI IMPUGNATURA BIMATERIALE

EXTRA LONG BENT NEEDLE KNURLED NOSE PLIERS BIMATERIAL HANDLES

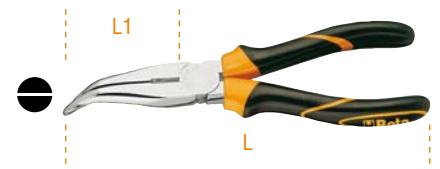

UNI 7926 Rif. BETA: 1168BM

ARTICOLO	L ~ mm	L1 mm	mm
70355	200	70	1,6

PINZE A BECCHI MEZZOTONDI LUNGHISSIMI PIEGATI ZIGRINATI MANICI RICOPERTI CON 2 STRATI DI PVC ANTISCIVOLO

EXTRA LONG BENT NEEDLE KNURLED NOSE PLIERS, CHROME-PLATED, HANDLES COATED WITH 2 LAYERS OF ANTISLIP PVC

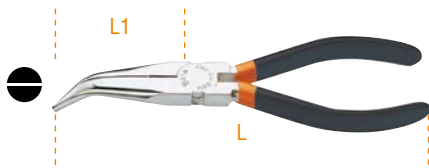

UNI 7926 Rif. BETA: 1168

ARTICOLO	L ~ mm	L1 mm	mm
70350	200	70	1,6

PINZE A BECCHI PIATTI LUNGHISSIMI PIEGATI ZIGRINATI IMPUGNATURA BIMATERIALE

EXTRA LONG BENT FLAT KNURLED NOSE PLIERS BIMATERIAL HANDLES

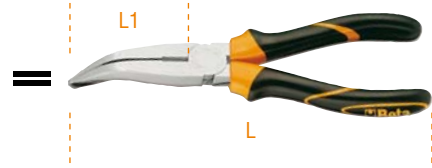

UNI 7925 Rif. BETA: 1164BM

ARTICOLO	L ~ mm	L1 mm	mm
70353	200	70	1,6

TRONCHESI A TAGLIENTI DIAGONALI IMPUGNATURA BIMATERIALE

DIAGONAL CUTTING NIPPERS, BIMATERIAL HANDLES

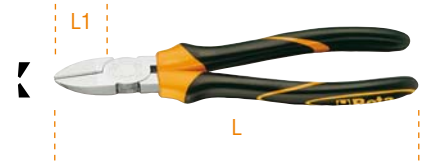

UNI/ISO 5749 Rif. BETA: 1082BM

ARTICOLO	L ~ mm	L1 mm	mm
70356	160	22	1,6

PINZE UNIVERSALI CROMATE LUCIDE IMPUGNATURA BIMATERIALE

COMBINATION PLIERS BRIGHT CHROME-PLATED BIMATERIAL HANDLES

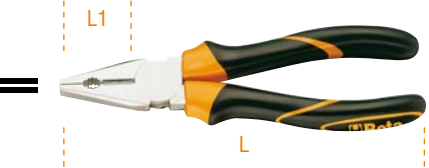

UNI 9894 - ISO 5746 Rif. BETA: 1150BM

ARTICOLO	L ~ mm	L1 mm	mm
70351	200	43	2,0

PINZE A BECCHI MEZZOTONDI LUNGHISSIMI DIRITTI ZIGRINATI IMPUGNATURA BIMATERIALE

EXTRA LONG NEEDLE KNURLED NOSE PLIERS BIMATERIAL HANDLES

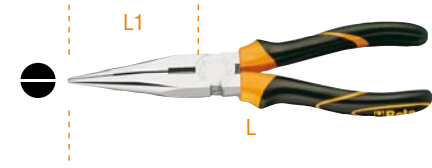

UNI 7926 - ISO 5745 Rif. BETA: 1166BM

ARTICOLO	L ~ mm	L1 mm	mm
70354	200	76	1,6

TRONCHESI A GRANDE EFFETTO A TAGLIENTI DIAGONALI IMPUGNATURA BIMATERIALE

HEAVY DUTY DIAGONAL CUTTING NIPPERS BI-MATERIAL HANDLES

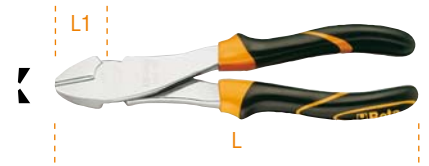

UNI/ISO 5749 Rif. BETA: 1084BM

ARTICOLO	L ~ mm	L1 mm	mm
70357	160	21	1,6
70358	200	26	2,0

TRONCHESE PER ELETTRONICA A TAGLIANTI DIAGONALI RASI BECCHI ASSOTTIGLIATI SCARICATI BRUNITO

DIAGONAL FLUSH CUTTING NIPPERS, SLIM TAPERING TIPS, BURNISHED FINISH

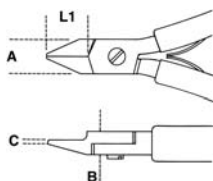

ISO 9654 Rif. BETA: 1186BM

ARTICOLO	L mm	L1 mm	A mm	B mm	C mm	Rame mm
70359	120	11	10	10	0,5	1,3

TRONCHESI A DOPPIA LEVA A TAGLIANTI FRONTALI TIPO PESANTE

TOGGLE LEVER ASSISTED END CUTTING NIPPERS, VARNISHED



UNI/ISO 5748 Rif. BETA: 1092V

ARTICOLO	L ~ mm	L1 mm	Rame mm
70360	200	10	2,5

TRONCHESI A DOPPIA LEVA A TAGLIANTI DIAGONALI TIPO PESANTE

TOGGLE LEVER ASSISTED DIAGONAL CUTTING NIPPERS, VARNISHED



UNI/ISO 5749 Rif. BETA: 1094V

ARTICOLO	L ~ mm	L1 mm	Rame mm
70361	200	23	2,5

TENAGLIE PER CEMENTISTI MANICI RICOPERTI IN PVC

TOWER PINCER

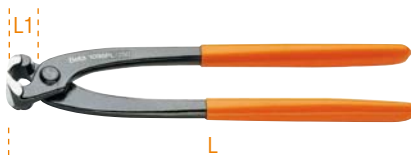

ISO 9242 - DIN 5242 Rif. BETA: 1098PL

ARTICOLO	L ~ mm	L1 mm
70362	250	15

CESOIA PER TAGLIO REGGIA

STRAP CUTTING SHEARS, BURNISHED FINISH



ISO 9242 - DIN 5242 Rif. BETA: 1118

ARTICOLO	L ~ mm	L1 mm
70363	310	42

FORBICI PER ELETTRICISTI LAME DRITTE

ELECTRICIAN'S SCISSORS, STRAIGHT BLADES



Rif. BETA: 1128BM

ARTICOLO	L mm	L1 mm
70364	145	58

FORBICI PER ELETTRICISTI LAME DRITTE IN ACCIAIO INOSSIDABILE

ELECTRICIAN'S SCISSORS, STRAIGHT BLADES, MADE FROM STAINLESS STEEL



Rif. BETA: 1128BMX

ARTICOLO	L mm	L1 mm
70365	142	44

TAGLIACAVI MANICI RICOPERTI CON 2 STRATI DI PVC ANTISCIVOLO PER TAGLIO DI CAVI ISOLATI DI RAME E ALLUMINIO

CABLE CUTTERS, CHROME-PLATED, PVC-COATED HANDLES



UNI 8791 Rif. BETA: 1132

ARTICOLO	L ~ mm	Rame mm
70366	170	10

MINI-TAGLIATUBI PER RAME E LEGHE LEGGERE

MINI PIPE CUTTER FOR COPPER AND LIGHT ALLOY PIPES



59 mm

Rif. BETA: 332

ARTICOLO	Ø mm	Ø
70367	3÷16	1/8"÷5/8"

PINZA TAGLIATUBI PER TUBI IN MATERIALE PLASTICO

PIPE CUTTING PLIERS FOR PLASTIC PIPES



Rif. BETA: 341

ARTICOLO	Ø mm	L mm
70368	0÷25	190

SEGHETTO

HACKSAW FRAME, CHROME-PLATED, STEEL FRAME, VARNISHED



Rif. BETA: 1725

ARTICOLO	
70369	

SEGHETTO SISTEMA DI TENSIONAMENTO DELLA LAMA INCORPORATO NELL'IMPUGNATURA

HACKSAW FRAME, VARNISHED STEEL FRAME

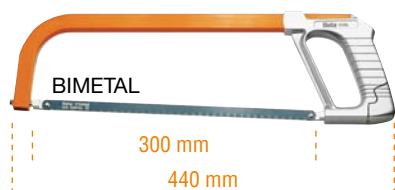

Rif. BETA: 1726

ARTICOLO	
70370	

SEGHETTO TIPO PESANTE

HACKSAW FRAME, HEAVY SERIES, VARNISHED



Rif. BETA: 1727

ARTICOLO	
70371	

CUTTER EXTRAPIATTO FORNITO CON 2 LAME DI RICAMBIO

EXTRA FLAT KNIFE, 9 MM SNAP-OFF BLADE, MADE FROM STAINLESS STEEL



Rif. BETA: 1770

ARTICOLO	
70372	

CUTTER

UTILITY KNIFE, 9 MM SNAP-OFF BLADE



Rif. BETA: 1770A

ARTICOLO	
70373	

CUTTER 18mm FORNITO CON 3 LAME DI RICAMBIO

UTILITY KNIFE, 3 SPARE BLADES



Rif. BETA: 1771

ARTICOLO	
70374	

CUTTER 18mm FORNITO CON 6 LAME DI RICAMBIO

UTILITY KNIFE, 6 SPARE BLADES



Rif. BETA: 1771BM

ARTICOLO	
70375	

10 LAME A SETTORI 18mm PER CUTTER 70374-70375

18MM SNAP-OFF SPARE BLADES (10) PIECES FOR UTILITY KNIVES 70374-70375

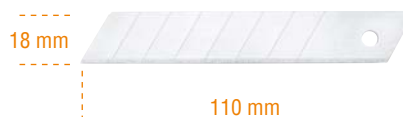

Rif. BETA: 1771RL

ARTICOLO	
70376	

PUNTE ELICOIDALI CILINDRICHE SERIE CORTA, IN ACCIAIO HSS RULLATE

HELICOIDAL TINES STEEL HSS



Rif. BETA: 410/SP19

ARTICOLO	
70377	Ø 1÷10x0,5 mm
70378	Ø 1÷13x0,5 mm

PUNTE ELICOIDALI CILINDRICHE SERIE CORTA, IN ACCIAIO HSS RETTIFICATE LUCIDE

HELICOIDAL TINES STEEL HSS



Rif. BETA: 412/SP25

ARTICOLO	
70379	Ø 1÷13x0,5 mm

PUNTE CONICHE PER FORARE ED ALLARGARE IN ACCIAIO HSS

CONICAL DRILL BITS



Rif. BETA: 424/SP3

ARTICOLO	
70380	Ø 3÷30 mm

FRESE CONICHE A GRADINO IN ACCIAIO HSS

HSS STEPPED DRILLS HSS



Rif. BETA: 425/SP3

ARTICOLO	
70381	Ø 4÷30 mm

MARTELLI TIPO TEDESCO PER MECCANICI MANICO IN LEGNO

ENGINEER'S HAMMERS, WOODEN SHAFTS



UNI 7778 - DIN 1041

Rif. BETA: 1370

ARTICOLO	g	H mm	L mm
70382	300	105	300
70383	500	118	320
70384	800	130	350
70385	1000	135	360

MAZZETTE MANICO IN LEGNO LUMP HAMMERS, WOODEN SHAFTS



UNI 7777 - DIN 6475

Rif. BETA: 1380

ARTICOLO	g	H mm	L mm
70386	800	90	260
70387	1000	95	260
70388	1250	100	260
70389	1500	110	280
70390	2000	120	300

MAZZUOLE CON BATTENTI INTERCAMBIABILI IN MATERIALE PLASTICO MANICO IN LEGNO

DEAD-BLOW HAMMERS WITH INTERCHANGEABLE
PLASTIC FACES, STEEL SHAFTS



UNI 7784

Rif. BETA: 1390

ARTICOLO	D mm	H mm	L mm
70391	35	95	310
70392	45	107	320
70393	60	128	380

CACCIASPINA

PIN PUNCHES, CHROME-PLATED



UNI 7502

Rif. BETA: 31

ARTICOLO	Ø mm	L mm	L1 mm
70394	2	110	22
70395	3	128	35
70396	4	146	45
70397	5	164	55
70398	6	182	65
70399	8	200	80
70400	10	220	95

BULINI

CENTRE PUNCHES, CHROME-PLATED



UNI 7503

Rif. BETA: 32

ARTICOLO	Ø mm	L mm
70401	3	100
70402	4	125
70403	5	150

SCALPELLI NERVATI

FLAT CHISELS, RIBBED TYPE, CHROME-PLATED



UNI 7506

Rif. BETA: 35

ARTICOLO	L mm	A mm
70404	150	20,5
70405	200	23,0
70406	250	28,5

SCALPELLO EXTRAPIATTO CON TAGLIENTE DIRITTO CON PARAMANO

EXTRA FLAT CHISEL WITH STRAIGHT CUTTER WITH
HAND GUARD

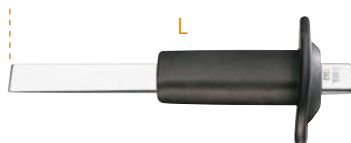

Rif. BETA: 1342PM

ARTICOLO	L mm
70407	118

ESTRATTORE AD ECCENTRICO PER VITI PRIGIONIERE

ECCENTRIC STUD EXTRACTOR, CHROME-PLATED



Rif. BETA: 1435

ARTICOLO	mm
70408	4÷20

ESTRATTORI UNIVERSALI A DUE GRIFFE TWO-LEG UNIVERSAL PULLERS, GALVANIZED



Rif. BETA: 1500N/...

ARTICOLO	L mm	A mm
70409	100	120
70410	150	170
70411	150	220
70412	205	360

ESTRATTORI A TRE GRIFFE THREE-LEG PULLERS, GALVANIZED

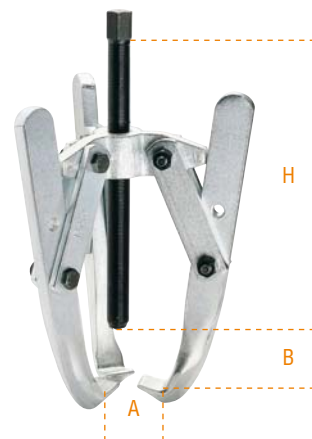

Rif. BETA: 1518/...

ARTICOLO	H mm	min A max mm	B max mm
70413	135	32 160	150
70414	235	40 220	220
70415	270	80 250	240

ESTRATTORI CONICI PER VITI E PRIGIONIERI SPEZZATI IN ACCIAIO LEGATO

SET OF TAPERED EXTRACTORS FOR BROKEN SCREWS AND STUDS

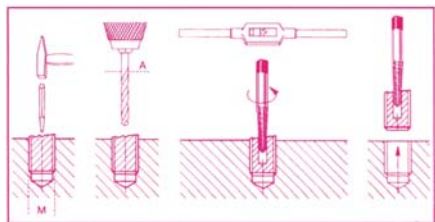

ARTICOLO	M mm	A mm
70474	3 ÷ 6	2,5
70475	6 ÷ 8	3
70476	8 ÷ 11	4,5
70477	11 ÷ 14	6
70478	14 ÷ 18	8
70479	18 ÷ 24	11
70480	24 ÷ 33	14
70481	33 ÷ 50	21



SERIE COMPOSTE DA 5 PZ./6 PZ.
Rif. BETA: 1430/S5 - 143/S6

ARTICOLO	M mm	A mm
70416	3÷6 / 6÷8	2,5 / 3,0
	8÷11 / 11÷14	4,5 / 6,0
	14÷18	8,0
70417	3÷6 / 6÷8	2,5 / 3,0
	8÷11 / 11÷14	4,5 / 6,0
	14÷18 / 18÷24	8,0 / 11,0

CALIBRO A CORSOIO LETTURA VENTESIMALE

WORKSHOP VERNIER, MADE FROM STEEL, IN SHEATH



ARTICOLO	S mm
70418	0,05 ÷ 1,00

CALIBRO DIGITALE A CORSOIO LETTURA CENTESIMALE

DIGITAL VERNIER

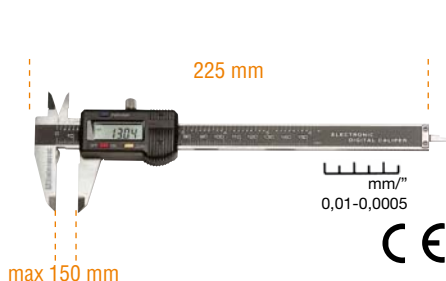

ARTICOLO	Rif. BETA
70419	1651SC

FLESSOMETRI CASSA IN ABS ANTIURTO

NASTRO IN ACCIAIO CLASSE PRECISIONE II

MEASURING TAPES, SHOCK-RESISTANT ABS CASINGS, STEEL TAPES, PRECISION CLASS II



ARTICOLO	L m	S mm
70422	3	16
70421	5	19

SPESSEMETRI

METRIC FEELER GAUGES



ARTICOLO	S mm
70423	0,05 ÷ 1,00

SMERIGLIATRICE ASSIALE

AXIAL SANDING MACHINE



Capacità pinza	3-6 mm
Velocità libera	25.000 giri/min
Potenza	0,20 Kw
Pressione d'utilizzo	6,2 bar
Consumo aria medio	230 l/min
Ø interno tubo aria	10 mm

Rif. BETA: 1933

ARTICOLO	PESO g
70424	620

SEGHETTO ALTERNATIVO SILENZIATO

AIR SAW, SILENCED



Corse al minuto	10.000
Lunghezza della corsa	10 mm
Pressione d'utilizzo	6,2 bar
Consumo aria medio	110 l/min
Ø interno tubo aria	8 mm

Rif. BETA: 1942A

ARTICOLO	PESO kg
70425	0,700

LAME BIMETAL PER SEGHETTO ALTERNATIVO

BIMETAL BLADES, 32 TEETH FOR AIR SAW



ARTICOLO	Rif. BETA
70426	1942LR

CRICCHETTO REVERSIBILE REVERSIBLE RATCHET



1/2"



Velocita' libera 150 giri/min
Coppia massima 68 Nm
Pressione d'utilizzo 6,2 bar
Consumo aria medio 140 l/min
Ø interno tubo aria 10 mm
Capacita' vite/dado CI 8.8 M10 ● 16 mm
Capacita' vite/dado CI 12.9 M8 ● 13 mm

Rif. BETA: 1921N3

ARTICOLO	PESO kg
70486	1,22

TRAPANO REVERSIBILE REVERSIBLE DRILL



Capacità mandrino 1±10 mm
Filettatura albero 3/8" - 24UNF
Velocità libera 1800 giri/min
Potenza 0,44 kw
Pressione d'utilizzo 6,2 bar
Consumo aria medio 160 l/min
Ø interno tubo aria 10 mm

Rif. BETA: 1932B10

ARTICOLO	PESO kg
70485	1,15

AVVITATORE REVERSIBILE IN MATERIE COMPOSITO REVERSIBLE IMPACT WRENCH, MADE FROM COMPOSITE MATERIAL



1/2"



Velocita' libera 7000 giri/min
Coppia massima 1020 Nm
Coppia d'esercizio 610 Nm
Attacco aria 1/4" GAS
Pressione d'utilizzo 6,2 bar
Consumo aria medio 130 l/min
Ø interno tubo aria 8 mm
Capacita' vite/dado CI 8.8 M22 ● 34 mm
Capacita' vite/dado CI 12.9 M18 ● 27mm

Rif. BETA: 1927CD

ARTICOLO	PESO kg
70483	

AVVITATORE REVERSIBILE IN MATERIE COMPOSITO REVERSIBLE IMPACT WRENCH, MADE FROM COMPOSITE MATERIAL



3/4"



Velocita' libera 4500 giri/min
Coppia massima 1800 Nm
Coppia d'esercizio 1290 Nm
Attacco aria 3/4" GAS
Pressione d'utilizzo 6,2 bar
Consumo aria medio 215 l/min
Ø interno tubo aria 10 mm
Capacita' vite/dado CI 8.8 M27 ● 41 mm
Capacita' vite/dado CI 12.9 M22 ● 34 mm

Rif. BETA: 1928CD

ARTICOLO	PESO kg
70484	

CASSETTE CON AVVITATORE REVERSIBILE E 4 BUSSOLE MACCHINA SERIE LUNGA REVERSIBLE IMPACT WRENCH - "PIN CLUTCH" IMPULSE DEVICE



1/2"

Meccanismo impulsivo "Pin Clutch"



Velocita' libera 10.000 giri/min
Coppia massima 770 Nm
Pressione d'utilizzo 6,2 bar
Consumo aria medio 122 l/min
Ø interno tubo aria 10 mm
Capacita' vite/dado CI 8.8 M22 ● 34 mm
Capacita' vite/dado CI 12,9 M18 ● 27 mm
Peso avvitatore 1,3 kg

Rif. BETA: 1927XM/K5

ARTICOLO	PESO kg
70427	



3/4"

Meccanismo impulsivo "Pin Clutch"

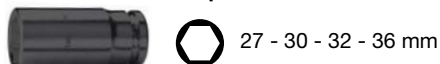

Velocita' libera 5000 giri/min
Coppia massima 1360 Nm
Pressione d'utilizzo 6,2 bar
Consumo aria medio 380 l/min
Ø interno tubo aria 10 mm
Capacita' vite/dado CI 8.8 M24 ● 36 mm
Capacita' vite/dado CI 12,9 M22 ● 34 mm
Peso avvitatore 5,1 kg

Rif. BETA: 1928K4

ARTICOLO	PESO kg
70428	

CHIAVE SNODATA A CATENA DOPPIA PER FILTRI OLIO

OIL-FILTER WRENCH WITH DOUBLE CHAIN, CHROME-PLATED

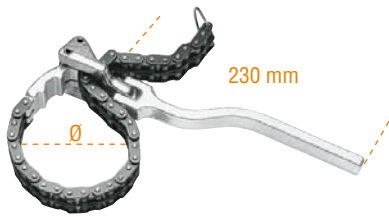

Rif. BETA: 1488

ARTICOLO	min	Ø	max
		mm	
70429	60		110

CHIAVE SNODATA A CATENA DOPPIA SOTTILE PER FILTRI OLIO

OIL-FILTER WRENCH WITH THIN DOUBLE CHAIN, CHROME-PLATED



Rif. BETA: 1488/1

ARTICOLO	min	Ø	max
		mm	
70430	60		110

CHIAVE A NASTRO PER FILTRI OLIO

STRAP WRENCH FOR OIL FILTERS



Rif. BETA: 1490/2

ARTICOLO	Ø max
	mm
70431	240

CHIAVE A NASTRO METALLICO REGOLABILE PER FILTRO OLIO

ADJUSTABLE OIL FILTER WRENCH, LIGHT ALLOY BODY



Rif. BETA: 1491

ARTICOLO	Ø
	mm
70432	65 ÷ 110

CHIAVI REGOLABILI PER FILTRI OLIO

ADJUSTABLE OIL FILTER WRENCHES



Rif. BETA: 1492/1 - 1492/2

ARTICOLO	Ø
	mm
70433	60 ÷ 80
70434	80 ÷ 110

PINZA PER CAPICORDA MODELLO LEGGERO CON ASSORTIMENTO DI 450 CAPICORDA

CRIMPING PLIERS, LIGHT SERIES, WITH ASSORTMENT OF 450 TERMINALS



Rif. BETA: 1602/C9T

ARTICOLO
70435

PINZA PER CAPICORDA NON ISOLATI APERTI MODELLO STANDARD

CRIMPING PLIERS FOR NON-INSULATED OPEN TERMINALS, STANDARD MODEL

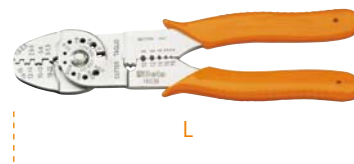

Rif. BETA: 1603B

ARTICOLO	L	
	mm	mm ²
70436	220	0 ÷ 8

LEVAGOMME

TYRE LEVERS, CHROME-PLATED



Rif. BETA: 962

ARTICOLO	L	A
	mm	mm
70437	500	27
70438	600	27

PISTOLA PER GONFIAGGIO PNEUMATICI

TYRE INFLATOR, ABS HOUSING



Rif. BETA: 1949GP

ARTICOLO
70439

COPPIE DI SPAZZOLE PER PULIZIA MORSETTI E POLI BATTERIA VEICOLI

PAIRS OF BATTERY LUG AND POST CLEANER STEEL BRUSHES



Rif. BETA: 1737B

ARTICOLO
70440

DENSIMETRO PER LIQUIDO ANTICONGELANTE

ANTIFREEZE DENSIMETER, GLASS BODY



Rif. BETA: 1759A

ARTICOLO
70441

DENSIMETRO PER LIQUIDI BATTERIA

ACID DENSIMETER, GLASS BODY



Rif. BETA: 1759B

ARTICOLO
70442

PROVATENSIONE VOLTAGE TESTER 3-48V

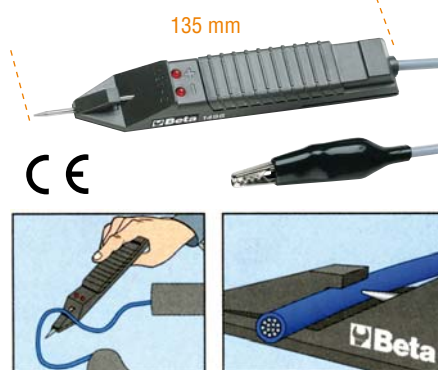

Rif. BETA: 1498

ARTICOLO	V
70443	3÷48

MULTIMETRO DIGITALE DIGITAL MULTI-METER



PARAMETRI RILEVABILI

Tensione DC 200 mV-2/20/200/1000V
Tensione AC 2-20/200/700V
Corrente DC 2/20/200 mA-20 A
Corrente AC 2/200 mA- 20 A
Resistenza 200Ω - 2/20/200 kΩ - 2/20 MΩ
Capacità 2/20/200 nF - 2/200 μF
Temperatura -20° + 1000°C
Frequenza 20kHz
Alimentazione 1 batteria da 9V (inclusa)

Rif. BETA: 1760B

ARTICOLO	
70444	

ATTREZZO BORDATUBI PER RAME E LEGHE LEGGERE

TUBE FLARING TOOL FOR COPPER AND LIGHT ALLOY PIPES

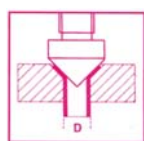

Rif. BETA: 352

ARTICOLO	D mm
70445	4,75-5-6-8-10-12-14

CASSETTIERA MOBILE CON 5 CASSETTI (VUOTA)

MOBILE ROLLER CAB WITH 5 DRAWERS (EMPTY)

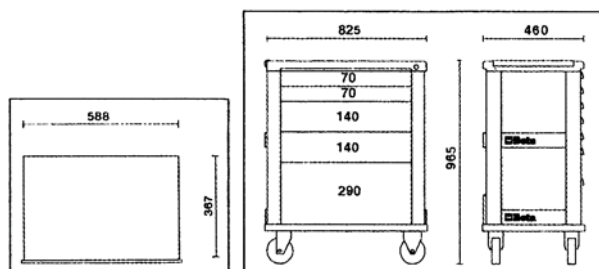

Caratteristiche principali:

- Cinque cassetti da 588x367 mm, montati su guide telescopiche a sfera:
 - 2 cassetti altezza 70 mm
 - 2 cassetti altezza 140 mm
 - 1 cassetto altezza 290 mm
- Piano dei cassetti protetto da tappetini di gomma espansa.
- Quattro ruote Ø 125 mm:
 - 2 fisse e 2 girevoli (una con freno).
- Serratura di sicurezza centralizzata frontale.
- Capacità di carico statico: 800 kg.
- Piano di lavoro termoplastico sul quale è collocabile a misura una cassetiera.
- Portaflacone laterale integrato.
- Possibilità di applicazione del portacarta.

Rif. BETA: C24S O/5

ARTICOLO
70446

CASSETTIERA MOBILE CON 7 CASSETTI (VUOTA)

MOBILE ROLLER CAB WITH 7 DRAWERS (EMPTY)

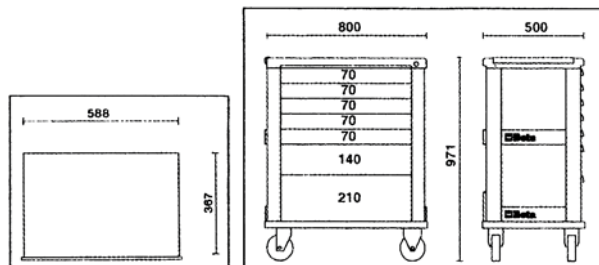

Caratteristiche principali:

- Sette cassetti da 588x367 mm, montati su guide telescopiche a sfera:
 - 5 Cassetti altezza 70 mm
 - 1 Cassetto altezza 140 mm
 - 1 Cassetto altezza 210 mm
- Piano dei cassetti protetto da tappetini di gomma espansa.
- Quattro ruote Ø 125 mm:
 - 2 fisse e 2 girevoli (una con freno).
- Serratura di sicurezza centralizzata frontale.
- Sistema di apertura posizionato su tutta la lunghezza del cassetto.
- Capacità di carico statico: 1200 kg.
- Piano di lavoro termoplastico.
- Portaflaconi laterali e posteriori integrati.
- Portacarta integrato.
- Montanti e frontalino del cassetto in alluminio.

Rif. BETA: C39 O

ARTICOLO
70447

CASSETTIERA PORTATILE CON 8 CASSETTI (VUOTA)

PORTABLE TOOL CHEST WITH 8 DRAWERS (EMPTY)



Caratteristiche principali:

- Otto cassetti montati su guide telescopiche a sfera:
- 4 cassetti altezza 50 mm
- 3 cassetti altezza 70 mm
- 1 cassetto altezza 100 mm.
- Serratura centralizzata frontale.
- Maniglie laterali a scomparsa per il trasporto.

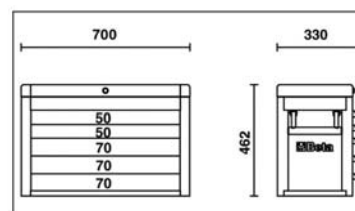

Rif. BETA: C23SC O

ARTICOLO
70448

TROLLEY PORTAUTENSILI A DUE MODULI SOVRAPPONIBILI (VUOTA)

TWO-MODULE TOOL TROLLEY (EMPTY)

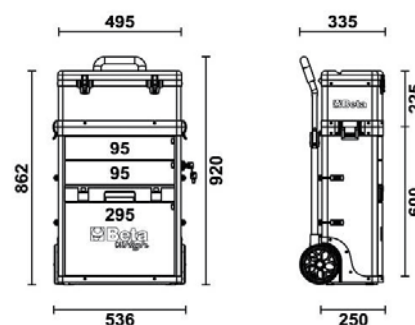

Caratteristiche principali:

- Struttura in lamiera e piani in materiale plastico: grande robustezza e peso ridotto.
- 2 moduli separabili:
 - 1 cestello superiore,
 - 1 modulo con 2 cassetti altezza 95 mm,
 - 1 cassetta estraibile in materiale plastico altezza 66 mm e 1 cassetto altezza 295 mm.
- Ruote di grosso diametro (160 mm),
- integrate nella struttura per facilitare il trasporto anche su gradini.
- Serratura centralizzata laterale per la chiusura dei cassetti del modulo inferiore.
- Cassetti montati su guide telescopiche a sfera con doppio gancio di chiusura.
- Impugnatura con manico telescopico in alluminio.
- Portaminuterie integrato nel cestello superiore.

Rif. BETA: C41H

ARTICOLO
70449